

PARTS LIST			
ITEM	QTY	PART NUMBER	DESCRIPTION
1	1	12702A	2" POLY PUMP VOLUTE
2	1	12703A	POLY PUMP REAR BRACKET
3	1	12705	PUMP CHECKVALVE, EPDM
4	1	12712AP	2" POLY PUMP BODY
4-1	2	12777	1/2" DRAIN PLUG
4-2	2	UV15163	#114 O'RING, EPDM
4-3	1	X12712A	2" POLY PUMP BODY
5	1	12716	PUMP SLINGER
6	1	12733	MECHANICAL SEAL ASSY
7	1	12772	IMPELLER
8	1	12910	DECAL (N/S)
9	1	KK-52	1-1/2", 2" & 3" PUMP MANUAL
10	1	PUMPKIT003	PUMPKIT
10-1	1	12710	AS268A -029 O-RING, EPDM
10-2	4	12715A	5/16-24 X 1 3/4" HHCS WITH TORQ-PATCH
10-3	4	12717	AS568A -011 O-RING, EPDM
10-4	1	12719A	AS568A -375 O-RING, EPDM, BLACK
10-5	10	12720	1/4-20 X 2 1/2" SL IND HWHS
10-6	2	12725	#6 X 1/2" PPH SMS
10-7	1	12754	O'RING SEGMENT
10-8	1	12765A	5/16-24 X 1 1/8" HFS
10-9	1	12775A	7/16-14 HEX NUT
10-10	1	12900	#10 X 1 1/2" PPH SMS
10-11	4	12901	5/16" FLAT WASHER
10-12	1	12902A	3/16" SQ. X 5/8" KEY
10-13	1	A204	AS568A -204 O-RING, EPDM, BLACK
10-14	10	V07018	1/4" LOCKWASHER
10-15	10	V07019	1/4-20 HEX NUT

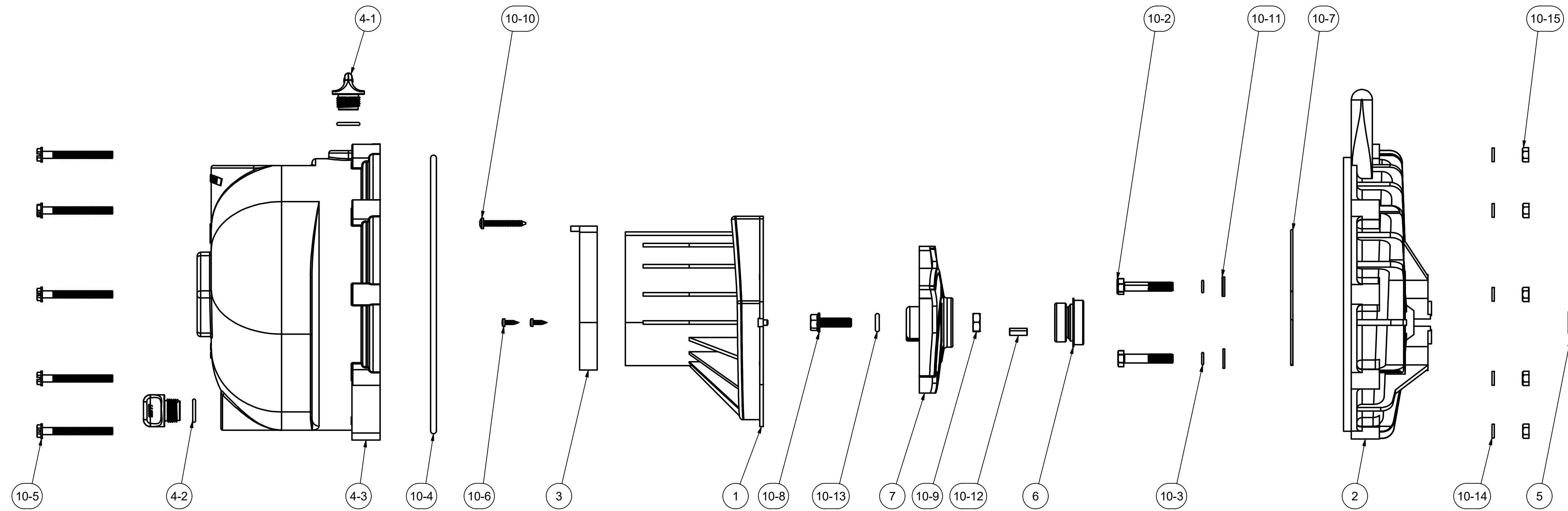

THIS DRAWING AND ALL INFORMATION CONTAINED THEREON ARE THE EXCLUSIVE PROPERTY OF BANJO CORPORATION.

UNLESS SPECIFICALLY NOTED, THIS DRAWING AND ITEMS SHOWN ON THIS DRAWING ARE SUBJECT TO CHANGE AT ANY TIME.

BANJO CORPORATION
 150 BANJO DRIVE, CRAWFORDSVILLE, IN 47933
 WEB SITE: WWW.BANJO.CORP.COM
 E-MAIL: BANJOSALES@DEXCORP.COM

DESCRIPTION
2" POLY PUMP ONLY W/ 5 VANE IMPELLER

PART NUMBER
205PO